

Award Winning Ecogate MASTER System

NEW



Ultimate in Dust Collecting

Average electricity savings 68%

<p>Function</p>	<p>When a machine is turned on, a sensor signals the greenBOX® controller to open the appropriate gate. When the machine stops, the gate closes. The greenBOX® MASTER monitors the usage of all machines in your shop and, through the Power MASTER™ unit continually optimizes the amount of power supplied to the collector fan. The system is programmed to keep a certain percentage of gates open to maintain proper airflow through the system.</p>
<p>Existing system</p>	<p>In case your plant has expanded and you are left with an undersize dust collector, the MASTER System can improve system performance, without the expense of making your system bigger.</p>
<p>New system</p>	<p>Your new dust collector can be designed 40% smaller than the standard design, or you can use conventional design size and this allows 40% expansion later.</p>

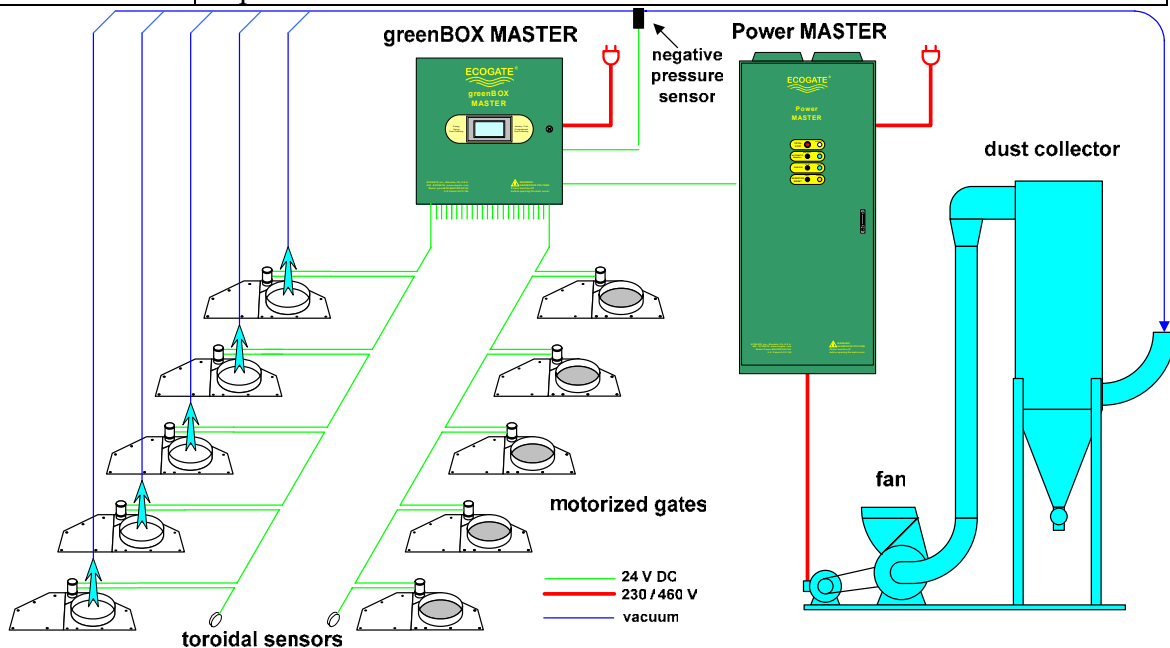

© 2001 - 2005, ECOGATE Inc., 1821 Tyburn St., CA 91204, U.S.A., 1-888-ECOGATE
 Phone: 818- 547 4007, Fax: 818- 547 4005, www.ecogate.com, Email: info@ecogate.com

ECOGATE, ECOGATE logo, greenBOX, ECOde are registered trademarks of ECOGATE, Inc.,
 Power MASTER is trademark of ECOGATE, Inc. U.S. patent 6,012,199 other patents pending.

Specifications

greenBOX MASTER computers	EG102, available models (fans x channels) a (1x22), b (1x44), c (2x22), d (4x11), e (1x88), f (2x44), g (4x22). Power supply 230V AC (from Power MASTER), industrial OMRON PLC with color touch screen, phone modem for system update & up/download of data.
Power MASTER units	Power supply 460V 3-phase. Inverter + contactor bypass. Input filter and line reactors included. Available models: EG112A, EG117A, EG125A, EG130A, EG140A, EG145A, EG160A, EG175A, EG190A, EG1110A, EG1150A, EG1180A, EG1210A, EG1260A, EG1300A, EG1370A, EG1500A, EG1670A. Explanation: model EG1300A maximum current is 300 Amps, rated approx. for 250 HP fan. Complete pre-engineered package ready for installation. Power MASTER units can be ordered with or without these options: input breaker, input filters, bypass contactors, isolating contactor for external soft start, star-delta soft start (requires motor with six outlets), Transport On Demand (to control filter and transport).
Gates	Compatible with Ecogates 5" to 16" and with pneumatically operated gates.
ECODE/i sensor interface	One sensor is required per workstation, sensors and gates are connected via CAT5 shielded wire to greenBOX computer. Toroidal sensor (coil) is used to monitor workstation activity.
Optional accessories	"Transport on Demand" to control transport fan or screw, air-lock, cleaning arm, cleaning air compressor in proper sequences and delays (according to dust collector manufacturer specification). Starts dust collector automatically when the first operator switches ON any workstation; and stops the dust collector automatically to save electricity.
DataMining PC software	The Ecogate System monitors energy usage as well as the activity of all workstations connected to the system. Measured values are recorded on a CompactFlash card; data can be downloaded via modem to any Windows PC with Ecogate DataMining™ software. DataMining software imports the downloaded data to a database, and every new data file is merged into the current database records and checked for duplicity. NEW (optional): LAN Ethernet card to transfer data from system to any PC on LAN (uses FTP server).

System Features: Updatable firmware; data collection on CompactFlash card; up to four Power MASTER units (fans) can be controlled by one greenBOX via serial line RS-485; system Auto-start /Auto-stop; password protected; direct touch screen or Windows PC programming; Fan start current reduction by using S-curve ramp; Fan shut off programmable delay; System maintains minimal air-flow; One button switch to MANUAL (bypass) operating mode; Interlock feature (if transport fan is not running, system stops automatically); "System Run" output for spark detection systems; Static pressure compensation for each gate; Computer RUN safety feature (if computer is not running correctly, Power MASTER is automatically stopped), "Negative pressure too high" safety feature; "All gates open in stop mode" safety feature; Modem communication (optional Ethernet LAN connection) with any Windows PC with Ecogate DataMining software (savings evaluation & workstation activity reports, firmware update, warnings & errors, service requests, plant efficiency evaluation, consumption and more); Savings of whole system settings to/from CompactFlash card (backup, documentation for customer & installer, setting); System can maintain values in three system branches for better system balancing; Advanced serial line communication between inverter and computer (kW, current to the motor, voltage, last error dump values); Help screen for each control page; Statistical functions (average # of running workstations, average power, etc.); History of errors and warnings accessible from touch screen; Warning for gates which are not operating correctly; Cleaning cycle is programmable branch by branch or whole system at once; Automated setup of inverter via greenBOX computer (much easier and time saving setup, prevention of programming errors); I/O boards for easier, faster, cost effective connection (plug-in terminals & color coding);

© 2001 - 2005, ECOGATE Inc., 1821 Tyburn St., CA 91204, U.S.A., 1-888-ECOGATE
 Phone: 818- 547 4007, Fax: 818- 547 4005, www.ecogate.com, Email: info@ecogate.com

ECOGATE, ECOGATE logo, greenBOX, ECODE are registered trademarks of ECOGATE, Inc.,
 Power MASTER is trademark of ECOGATE, Inc. U.S. patent 6,012,199 other patents pending.

Test switches (input enable, run) & Indicators for faster debugging; Variable speed drive error messages are displayed on greenBOX MASTER screen in plain English.

© 2001 - 2005, ECOGATE Inc., 1821 Tyburn St., CA 91204, U.S.A., 1-888-ECOGATE
Phone: 818- 547 4007, Fax: 818- 547 4005, www.ecogate.com, Email: info@ecogate.com

ECOGATE, ECOGATE logo, greenBOX, ECOde are registered trademarks of ECOGATE, Inc.,
Power MASTER is trademark of ECOGATE, Inc. U.S. patent 6,012,199 other patents pending.